



Survey on performance parameters of planar microwave antennas

Ravi Kumar^{1*}, Anchal Garg², Heli Shah³ and Bhupinder Kaur⁴



¹Department of Electronics and Communication Engineering, Faculty of Engineering and Technology, Jain (Deemed-to-be University), Bengaluru, India; ²Department of Electronics and Communication Engineering, Dev Bhoomi Uttarakhand University, Dehradun, Uttarakhand, India; ³Department of Mechatronics Engineering, Parul Institute of Technology, Parul University, Vadodara, Gujarat, India; ⁴Department of Electronics & Communication Engineering, Chandigarh Engineering College, Jhanjeri, India

E-mail/Orcid Id:

RKS, s.ravikumar@jainuniversity.ac.in, <https://orcid.org/0000-0001-9617-6702>;

AG, ece.aanchal@dbuu.ac.in, <https://orcid.org/0000-0001-7473-0960>;

HS, eli.shah165006@paruluniversity.ac.in, <https://orcid.org/0000-0003-3290-6555>;

BK, bhupinder.j1898@cgc.ac.in, <https://orcid.org/0000-0001-7627-3214>

Article History:

Received: 18th Mar., 2023

Accepted: 30th Jun., 2023

Published: 30th Jul., 2023

Keywords:

Antenna, Planar device, Microwave, Polarization, Electromagnetic field, High-frequency applications.

Abstract: Planar antennas, which include microstrip antennas and printed circuit board antennas, are used in telecommunications. This study aims to provide an overview of microstrip antennas for diverse applications. Microstrip patch antenna design is a new study topic that has been established for usage in 5th-generation communication applications. An antenna is a group of connected devices that serve as a single antenna to broadcast or receive radio waves. Antennas come in a variety of designs and sizes. The paper discusses several printed microstrip antenna designs, such as rectangular to circular, broadband, dual-band, millimeter-wave and microstrip arrays. The microstrip patch is an antenna layout that is lightweight, low-profile, and results-oriented. Microstrip patch antennas may be employed in various 6G communication system applications in the future. This paper examines antenna geometric structures, antenna analysis methodologies, antenna dimensions and many different types of antennas. It will also go over the substrate materials, loss tangent, thickness, return loss, bandwidth, voltage-standing-wave-ratio (VSWR), gain, and directivity so that an optimized antenna can be designed and fabricated having excellent characteristics for use in modern applications by the promising academic researchers in the near future.

Introduction

Microstrip technology began in 1953 but became very popular later, especially after 1972. The most essential benefit of microstrip devices and circuits is their low profile, and it helps to be used in portable handheld devices and various wireless communication systems. It is widely used in mobiles, walkie-talkies, GPS, RFID, and healthcare monitoring devices. Planar devices are considered as low or very negligible height transmission lines. Microstrip antenna is one such device that has a height of nearly 0.01mm. Such devices are fabricated by mounting a conducting patch, preferably copper material, on top of a non-conducting material called a dielectric substrate (Balanis, 1992). The substrate height also varied according to different application types and was nearly

1.6mm. The permittivity value also plays a major role in the performance of an antenna and generally varies between 2.2 to 10.7 (Rashid & M. Jassim Al-Hindawi, 2019). As the permittivity increases, the overall dimension of a microstrip component decreases (Milligan, 2005). Hence it can be concluded that the permittivity factor of a patch antenna is in reverse proportional to the length-width of that particular antenna. Some substrates are found on Earth naturally, but most are developed in laboratories by sophisticated methods (Hossain et al., 2020).

At the beginning of research on microstrip technology, the substrate height was high and the material was fat, which permitted non-transverse electromagnetic waves to propagate, producing a very unwanted and ambiguous



response (Islam et al., 2018; Sasaki et al., 2016; Sun et al., 2021). The conventional microstrip patch antenna (MPA) consists of a transmitting patch that emits electromagnetic (EM) waves placed on top of a dielectric material as shown in Figure 1. In 1953 the head of an antenna laboratory, University of Illinois Prof. Georges Armand Deschamps, proposed the idea of the microstrip antenna (Lo et al., 1979). However, the first antenna was invented in the 1970s when good-quality substrates became obtainable (Simba et al., 2007). Since then, much research and development has been done to make MPAs the most desirable alternatives in various microwave component designs. The area of antenna design is still undergoing a lot of development (Kuo and Wong, 2001).

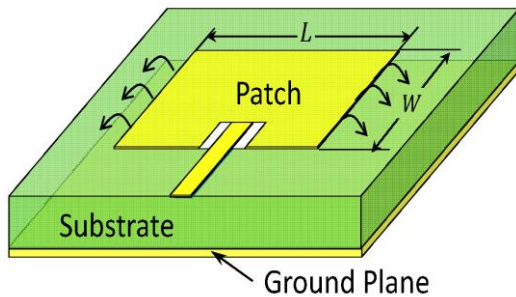

Figure 1. A typical microstrip patch antenna is used for microwave applications (El Gharbi et al., 2020)

Patch antenna is named so because an antenna is formed by etching out a patch of conductive element on top of the surface of a non-conducting material. The dielectric part is mounted on top of a conductive strip called 'the ground plane', which supports the complete structure (Volakis, 2012). The antenna is excited by a feeding method and an electrical signal is directly applied to the antenna through feed lines. This type of structure can be fabricated using conventional printed circuit board

patch elements, the dielectric medium's different parameters, and the type of excitation or feeding technique to avail energy to the microstrip antenna. The same numerical analysis is associated with the design of many other microstrip devices, such as planar filters, power dividers, couplers, resonators, terminators etc. So, it is clear that microstrip technology can be used to implement microwave active and passive devices (Hassan et al., 2015; Khan et al., 2022).

Once the microstrip patch's width and length are calculated, the actual design can be prepared using a high-performance software tool and subsequently simulated. The results produced after the simulation is over need to be stored properly for analysis later (Ramesh and Yip, 2003). AutoCAD tool fabricates the patch antenna physically with proper dimensions as taken during simulation. Once the patch antenna design is completed, it must be simulated using commercially available software such as IE3D, HFSS, CST Microwave Studio, etc. At the end, the patch antenna may be fabricated using a traditional printed circuit board mechanism if found satisfactory in all respects.

A planar microwave antenna is one of the widely used microstrip devices found today. Microstrip antennas are used for high-frequency applications, also called patch antennas as it is mounted on a dielectric material. However, for effective use of a microstrip antenna, it is important to know its technical features such as gain, directivity, radiation pattern, polar pattern, reflection coefficient, nature of polarization, etc. It is highly required to analyze each of these parameters to improve the overall performance of a microstrip patch antenna for

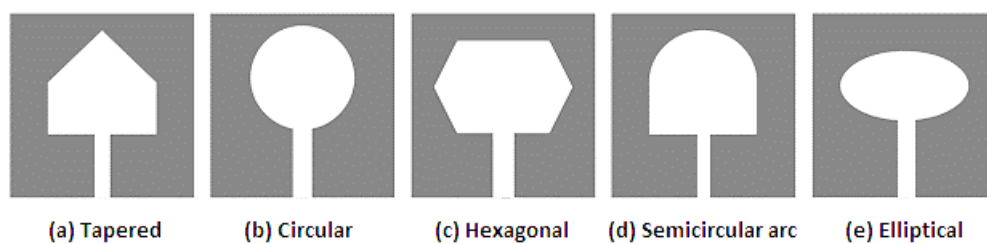

Figure 2. Different shapes for microstrip patch antenna (Balanis, 1992)

design. Some of the widely used antenna patch shapes for practical high-frequency applications are shown below in Figure 2.

These patch shapes of conducting materials have their respective radiation parameter and characteristics (Iftissane et al., 2011). The choice of a particular shape is based on certain requirements such as gain, directivity, radiation pattern, polarization, transmission coefficient, reflection coefficient etc. Mathematical expressions are used to calculate the various dimensions of conducting

transmitting and receiving microwave signals faithfully. The objective of this paper is to introduce the concept of planar antennas to new researchers and to provide a detailed analysis as well as an understanding of various technical parameters associated with a conventional microstrip planar antenna so that an optimized antenna can be designed and fabricated with having excellent characteristics for use in modern applications, by the promising antenna designers in the days to come (Matta et al., 2022).

Performance Parameters of a Patch Antenna

A planar microwave antenna has different operating characteristics. These essential characteristics help to understand the performance of a designed patch antenna as these essential values are compared with standardized values obtained earlier from reliable sources like literature published by researchers around the globe, both in soft or hard form. It is regulatory to find these parameters for any patch antenna (Alibakhshikenari et al., 2020; M. M. Hossain et al., 2022).

Basic operating principle

An acoustic cavity is created within and around a conducting patch. A transmitting patch's borders are nothing more than the cavity's margins. Under operating circumstances, the patch's edges function as an open circuit (Esmail et al., 2022). This time, the parameters are quite useful in understanding the patch antenna's behaviour and in studying it. The electrical field mostly propagates along the z-axis and in the z-direction within the patch cavity. The surface electrical field vector formulation for the (m, n) cavity mode of the L-long patch may be stated as follows:

$$E_z(x, y) = A_{mn} \cos\left(\frac{m\pi x}{L}\right) \cos\left(\frac{n\pi y}{W}\right) \dots \dots \dots (1)$$

L is equal to conducting patch length and W is the "patch width" in the above formula. Then, on the x-axis, the surface wave current under the metallic patch is given

$$\text{by: } J_{sx}(x) = A_{10} \left(\frac{\pi/L}{j\omega\mu_0\mu_r} \right) \dots \dots \dots (2)$$

In this mode of operation, the patch is considered a microstrip line. W is usually chosen to be of high value than the actual length of the conducting patch (with $W = 1.5L$) to increase the bandwidth and as the bandwidth is directly proportional to the width, the present is max at the center of the patch, "x is equal to $L/2$ ", while the electric field is found to be high at both the edges, " $x = 0$ and $x = L$ ". From the beginning look, the microstrip receiving wire won't work as a radiator once the substrate is electrically slender since the fixed flows are successfully arranged. The reverberation plentifulness of the modular field is contrarily corresponding. Along these lines, the field power of the transmitted field compared to the fix is fundamental without l when extra prospects are thought about. Moreover, the thunderous information obstruction might be near without h. This makes sense of why a fixed receiving wire is a productive radiator in any event for slender substrates, regardless of whether the deliberate measurements are adequate.

Resonant frequency

This parameter is the most important one in the design of a patch antenna for microwave communications. At this frequency, the reactive components cancel out each other hence making the component completely resistive and ready to vibrate and generate oscillation as desired. The resonant frequency expression can be written as:

$$f_0 = \frac{c}{2L_e \sqrt{\epsilon_r}} \dots \dots \dots (3)$$

Where c is the "speed of light". To calculate the "effective length" of the patch we need to consider the fields existing at the edges of the patch and use the following expression where L is the physical length of the conducting patch:

$$Le = L + 2\Delta L \dots \dots \dots (4)$$

The Schneider-Hammerstad formula used for resonant frequency calculation is:

$$\frac{\Delta L}{h} = 0.412 \left[\frac{(\epsilon_{eff} + 0.3) \left(\frac{W}{h} + 0.264 \right)}{(\epsilon_{eff} - 0.258) \left(\frac{W}{h} + 0.8 \right)} \right] \dots \dots \dots (5)$$

Where,

$$\epsilon_{eff} = \frac{\epsilon_r + 1}{2} + \frac{\epsilon_r - 1}{2} \left(1 + \frac{12h}{W} \right)^{-1/2}$$

Radiation pattern

It is nothing more than a change in the amount of power that is emitted in various aerial directions, and it aids in determining further features of an antenna. If we suppose that the isotropic antenna radiates power P, then the power is dispersed across a sphere of radius r. Consequently, the power density S in this direction at this distance may be:

$$s = \frac{P}{4\pi r^2} \dots \dots \dots (6)$$

Isotropic antennas aren't realizable in observation however will be utilized as a relevant compare the performance of sensible antennas (M. S. Rana & Smiee, 2022). As can be seen in Figure 3, the pattern offers information on the antenna resolution, aspect lobes, and beamwidth to an excessive degree.

E-plane patterns are graphical representations of antenna radiation operating in an extraordinary plane, including a radius vector from the antenna's centre to the direction receiving the bulk of radiation and, therefore, a vector for the field strength. The H plane pattern will also be constructed while considering the field of force intensity vector.

Gain of antenna

Antenna gain provides information about the power transmitted in a particular direction to the power generated by an isotropic antenna which has unity gain and radiates equal power in all directions. The intensity

of RF power emitted in a certain direction is what is truly described by the gain. The multiplication of directivity and the corresponding efficiency can also be used to represent the antenna gain. This is how the antenna gain is expressed:

$$G_{\theta, \phi} = \frac{P(\theta, \phi)}{\frac{W_t}{4\pi}} \dots\dots\dots (7)$$

Where W_t is the total radiated power as well as (θ, Φ) is the power emitted per unit “solid angle” in the direction of (θ, Φ) . Micro-strip antennas have low gain by design because of their poor radiation efficiency. A lot of effort is being made in this subject worldwide to create

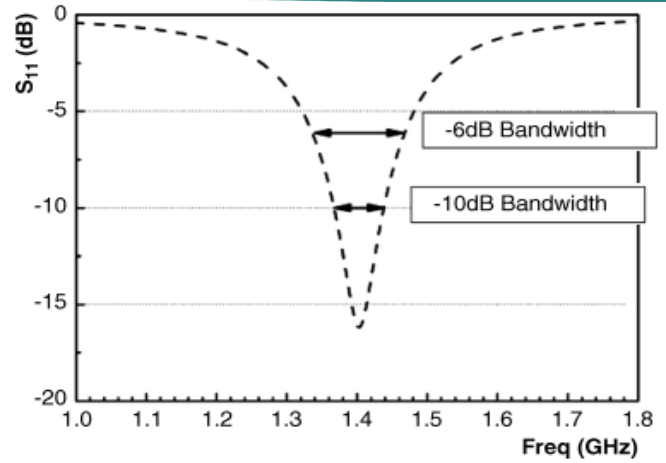

Figure 4. Bandwidth representation for an antenna

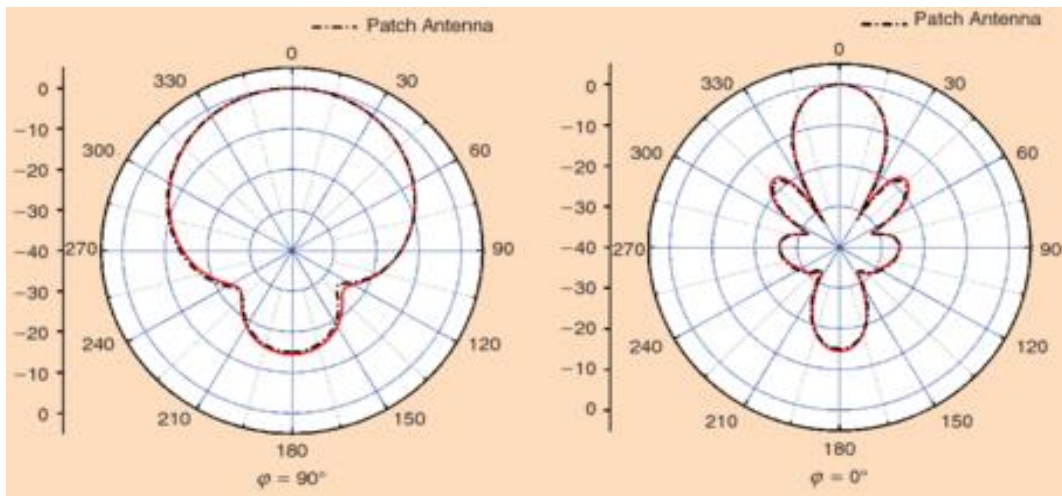

Figure 3. Typical radiation pattern of a patch antenna at different values of ‘ Φ ’ (Gao et al., 2015)

antennas with a high gain.

Directivity of an Antenna

It is one of the fundamental parameters of a microwave antenna which describes how focused the antenna output power is in a particular direction. It is calculated from the power density in a three-dimensional space and is mostly expressed in decibels (dB). The mathematical equation can be written as:

$$D = \frac{P_{max}}{P_{avg}} \dots\dots\dots (8)$$

There is a simple relationship between directivity as well as the gain of a patch antenna which is mentioned below:

$$D = \eta G \dots\dots\dots (9)$$

Where, η is the antenna efficiency.

The bandwidth of a planar antenna

The word bandwidth describes the whole range of working frequencies that the antenna operates within, in compliance with certain key characteristics, as per a stated standard (Malik, 2021; Behera and Salkuti, 2022). The bandwidth is defined mathematically as the ratio of the greatest operational frequency to the lowest operating frequency. Figure 4 illustrates how the bandwidth of various kinds of antennas is represented as:

$$\text{Bandwidth of the Broadband} = \frac{F_h}{F_l} \dots\dots\dots (10)$$

$$\text{Bandwidth of the Narrowband \%} = \frac{F_h - F_l}{F_c} \times 100 \dots\dots (11)$$

Where, F_l is the lower frequency F_h is the greater frequency, as well as F_c the centre frequency.

Return loss characteristics

This parameter is very much essential for the antenna as it provides the radiation details. The signal power that is radiated by the antenna is expressed in terms of transmission coefficient and the same is expressed in dB as insertion loss (Ranaweera et al., 2019). And the reciprocal of insertion loss is known as return loss. Figure 5 illustrates how a suitable microstrip patch antenna should have a return loss of less than ten dB.

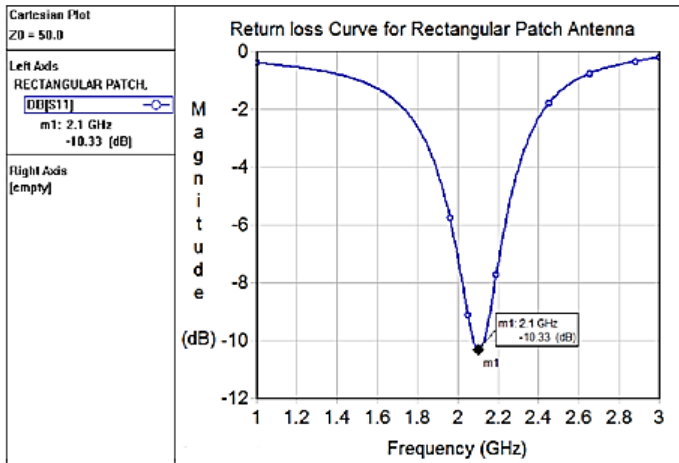

Figure 5. Typical return loss plot for a rectangular patch antenna at 2.1 GHz (Roy et al., 2013)

The parameter reflection co-efficient is closely associated with the return loss as below:

$$R_L dB = 10 \log \frac{P_r}{P_i} \dots\dots\dots (12)$$

Where, P_i is equal to the power applied by the source and the power reflected to the source of the antenna.

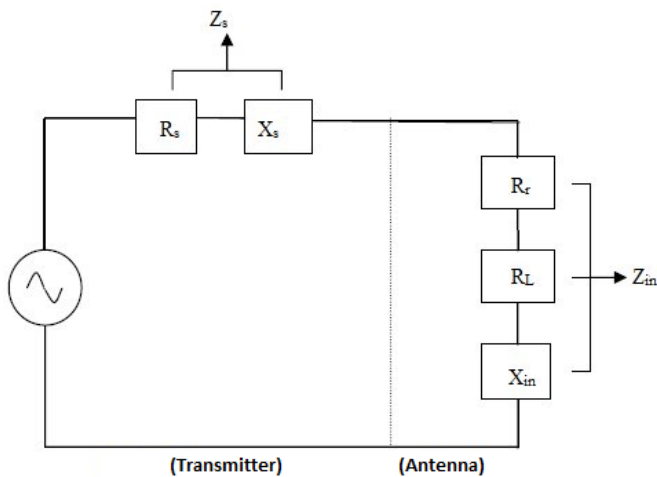

Figure 6. Equivalent circuit of a transmitting antenna (S. Rana et al., 2016)

A receiving antenna's equivalent circuit consists of a current generator and two admittances: one for the load and one for the antenna. The short-circuit current, receiving property, current, voltages etc. can be stated in terms of the antenna's transmitting qualities (An & He,

2020; Cui et al., 2014). The standard equivalent circuit models based on the Thévenin or Norton theorem are shown to be unsuitable for a receiving antenna system because a voltage or current source cannot simply approximate the antenna (Martin-Anton & Segovia-Vargas, 2020).

Voltage Standing Wave Ratio (VSWR)

Standing waves are generated when a transmitted wave reflects the microwave source due to the impedance mismatching at the terminal. It means that the “Voltage Standing Wave Ratio” (VSWR) is a parameter that represents how fine the antenna impedance is matched to the radio (Bansal and Gupta, 2020). We know that the source impedance and load impedance must be exactly matched for the maximum power to be delivered to the load or antenna, as illustrated in Figure 6.

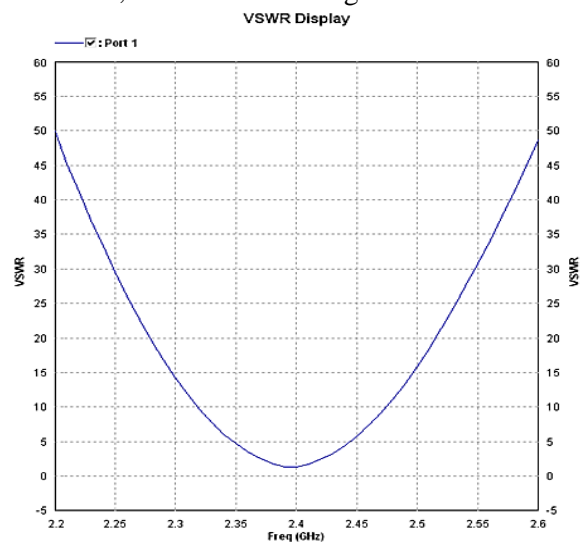

Figure 7. Simulated VSWR plot with respect to frequency in GHz [Drone Cosmo]

If the impedance offered by the antenna is assumed as Z_{in} and the source impedance is assumed as Z_s then the condition for matching load can be written as:

$$Z_{in} = Z_s$$

Where, $Z_{in} = R_{in} + jX_{in}$ as well as $Z_s = R_s + jX_s$

In case of impedance mismatch, part of the incident power is reflected and the following expressions characterize the same:

$$VSWR = \frac{1 + |\Gamma|}{1 - |\Gamma|} \dots\dots\dots (12)$$

$$\Gamma = \frac{V_r}{V_i} = \frac{Z_{in} - Z_s}{Z_{in} + Z_s} \dots\dots\dots (13)$$

Where, Γ denotes the reflection coefficient
 V_r denote the amplitude of the reflected wave
 V_i denote the amplitude of the incident wave

The VSWR is primarily an instrument for measuring the impedance mismatch between the transmitter and the antenna. It is clear from Figure 7 that the higher value of VSWR leads to a greater mismatch of corresponding impedances. The minimum value VSWR indicates a perfect match and the absolute is around unity. Because most microwave devices are manufactured for this impedance, antenna designers commercially prefer to maintain the input impedance at 50 ohms (Godaymi Al-Tumah et al., 2022).

Quality factor or Q factor

The quality factor of a planar microstrip radiator is described as the ratio of the total energy stored in the reactive field to the energy radiated by the antenna. Mathematically, the quality factor is expressed as:

$$Q = \frac{2W_{max}(W_M W_E)}{P} \dots\dots\dots (14)$$

Where,
 W_M = stored magnetic energy
 W_E = stored energy and P is the radiated power.

Quality factor issue is employed to see the losses of a patch antenna. Typically there are four varieties of losses in an antenna that are essential to consider in designs: radiation loss, ohmic loss, non-conductor loss and surface wave losses (Ravipati & Shafai, 1999). The semiconducting losses square measure directly proportional to the peak of the substrate and radiation losses square measure reciprocally proportional to the height of the substrate. The antenna's information measure will increase once the substrate's nonconductor height increases. At a constant time, the semiconducting losses will also increase. Once the peak of the substrate decreases, the radiation loss becomes vital. The quality factor is significant when the antenna is used for high-performance microwave systems (Iwasaki and Chiba, 1999).

The efficiency of the Antenna

Antenna efficiency is calculated during the design of a microwave antenna to take stock of the losses that occur during its operations. Some losses are generated due to deflections in the materials used for antenna fabrication (Park and Jung, 2022). Whereas some of the losses are found during the operation of the antenna.

- Return losses due to a mismatch of the transmitter line as well as the antenna
- I^2R losses

Hence the total antenna efficacy: $e_t = e_r + e_c + e_d$;

Where, e_t Donates a whole antenna efficiency

$e_r = (1 - |\Gamma|^2)$ = Reflection (mismatch) efficiency

e_c Donates a Conduction efficiency

e_d Donates a Dielectric efficiency

Subsequently, as well as e_d being problematic to separate, they are lumped together to form the e_{cd} effectiveness which is given as:

$$e_{cd} = e_c e_d = \frac{R_r}{R_r + R_L} \dots\dots\dots (15)$$

Here, e_{cd} is called the antenna radiation efficiency as well as is well-defined as a relation of the power supplied to the “radiation resistance” R_r , to the power distributed to the sum of resistances, R_r as well as R_L .

This paper focuses on recent breakthroughs in planar antenna design and its applications in several study disciplines, such as space communication, mobile communication, wireless communication, and wearable applications. Medical uses for planar antennas include microwave imaging, medical implants, hyperthermia therapies, and wireless wellness monitoring. Despite their considerable application potential, most of these applications continue to utilize cumbersome antenna systems, which limit their efficiency and usability. This research also covers planar antenna design concepts, methods and approaches for improving performance parameters, and applications for IoTs and device-to-device communication. Efforts have been made to cover particular steps for resolving antenna design challenges and how to create conformal and miniaturized antenna systems for diverse applications.

Conclusion

Antennas have become an essential component of the telecommunications sector. Hence the performance of a microwave planar antenna makes a huge impact on the

overall communication system performance and needs to be improved by optimizing its design parameters. This paper provides an insight view of a typical microwave planar antenna and investigates several technical parameters that affect such an antenna's response. The architecture of microstrip devices is such that scientists and researchers must have proper knowledge of all the performance parameters related to a particular antenna. The relationship of these parameters with the outcome of an antenna is also discussed such as directivity value is directly proportional to the amount of microwave power propagated in free space. Another parameter transmission coefficient is inversely proportional to the antenna loss as it defines the relationship between the antenna input and output power. Hence it is concluded that each of these performance parameters must be individually calculated while designing a microwave planar antenna for practical applications.

Conflict of interest

None

Acknowledgements

The authors express their gratitude to their mentors, colleagues and authorities for their valuable suggestions and guidance in this research work.

References

- Alibakhshikenari, M., Virdee, B. S., Shukla, P., Parchin, N. O., Azpilicueta, L., See, C. H., Abd-Alhameed, R. A., Falcone, F., Huynen, I., Denidni, T. A., & Limiti, E. (2020). Metamaterial-inspired antenna array for application in microwave breast imaging systems for tumor detection. *IEEE Access*, 8, 174667 - 174678. <https://doi.org/10.1109/ACCESS.2020.3025672>
- An, Z., & He, M. (2020). A simple planar antenna for sub-6 GHz applications in 5G mobile terminals. *Applied Computational Electromagnetics Society Journal*, 35(1), 10-15.
- Balanis, C. A. (1992). Antenna Theory: A Review. *Proceedings of the IEEE*, 80(1), 7-23. <https://doi.org/10.1109/5.119564>
- Bansal, A., & Gupta, R. (2020). A review on microstrip patch antenna and feeding techniques. *International Journal of Information Technology*, 12(1), 1-6. <https://doi.org/10.1007/s41870-018-0121-4>
- Behera, K. R., & Salkuti, S. R. (2022). Microstrip antenna optimization using evolutionary algorithms. *IAES International Journal of Artificial Intelligence*, 11(3), 836-842. <https://doi.org/10.11591/ijai.v11.i3.pp836-842>
- Cui, Y. H., Li, R. L., & Fu, H. Z. (2014). A broadband dual-polarized planar antenna for 2G/3G/LTE base stations. *IEEE Transactions on Antennas and Propagation*, 62(9), 4836-4840. <https://doi.org/10.1109/TAP.2014.2330596>
- El Gharbi, M., Fernández-García, R., Ahyoud, S., & Gil, I. (2020). A review of flexible wearable antenna sensors: Design, fabrication methods, and applications. In *Materials*, 13(17), 3781. <https://doi.org/10.3390/MA13173781>
- Esmail, B. A. F., Koziel, S., & Szczepanski, S. (2022). Overview of Planar Antenna Loading Metamaterials for Gain Performance Enhancement: The Two Decades of Progress. *IEEE Access*, 10, 27381-27403. <https://doi.org/10.1109/ACCESS.2022.3157634>
- Gao, S. P., Wang, B., Zhao, H., Zhao, W. J., & Png, C. E. (2015). Installed Radiation Pattern of Patch Antennas: Prediction based on a novel equivalent model. *IEEE Antennas and Propagation Magazine*, 57(3), 81-94. <https://doi.org/10.1109/MAP.2015.2437275>
- Godaymi Al-Tumah, W. A., Shaaban, R. M., & Duffy, A. P. (2022). Design, simulation, and fabrication of a double annular ring microstrip antenna based on gaps with multiband feature. *Engineering Science and Technology, an International Journal*, 3(3), 10. <https://doi.org/10.1016/j.jestch.2021.06.013>
- Hassan, E., Noreland, D., Augustine, R., Wadbro, E., & Berggren, M. (2015). Topology Optimization of Planar Antennas for Wideband Near-Field Coupling. *IEEE Transactions on Antennas and Propagation*, 18, 1-6. <https://doi.org/10.1109/TAP.2015.2449894>
- Hossain, A., Islam, M. T., Islam, M. T., Chowdhury, M. E. H., Rmili, H., & Samsuzzaman, M. (2020). A planar ultrawideband patch antenna array for microwave breast tumor detection.

- Materials*, 13(21), 4918.
<https://doi.org/10.3390/ma13214918>
- Hossain, M. M., Alam, M. J., & Latif, S. I. (2022). Orthogonal Printed Microstrip Antenna Arrays for 5G Millimeter-Wave Applications. *Micromachines*, 13(1), 53.
<https://doi.org/10.3390/mi13010053>
- Iftissane, M., Bri, S., & Mamouhi, A. (2011). Design and modelling of broad band patch antenna. *Modelling, Measurement and Control A*, 11(2), 16-80.
- Islam, M. T., Ullah, M. A., Alam, T., Singh, M. J., & Cho, M. (2018). Microwave imaging sensor using low profile modified stacked type planar inverted F antenna. *Sensors (Switzerland)*, 18(9), 2949.
<https://doi.org/10.3390/s18092949>
- Iwasaki, H., & Chiba, N. (1999). Circularly polarised back-to-back microstrip antenna with an omnidirectional pattern. *IEE Proceedings: Microwaves, Antennas and Propagation*, 146(4), 277-281. <https://doi.org/10.1049/ip-map:19990568>
- Khan, M. A., Rafique, U., Savci, H. Ş., Nordin, A. N., Kiani, S. H., & Abbas, S. M. (2022). Ultra-Wideband Pentagonal Fractal Antenna with Stable Radiation Characteristics for Microwave Imaging Applications. *Electronics (Switzerland)*, 11(13), 2061.
<https://doi.org/10.3390/electronics11132061>
- Kuo, Y. L., & Wong, K. L. (2001). A circularly polarized microstrip antenna with a photonic bandgap ground plane. *Asia-Pacific Microwave Conference Proceedings, APMC*, 3, 17-27.
<https://doi.org/10.1109/apmc.2001.985456>
- Lo, Y. T., Solomon, D., & Richards, W. F. (1979). Theory and Experiment on Microstrip Antennas. *IEEE Transactions on Antennas and Propagation*, 27, 137-145.
<https://doi.org/10.1109/TAP.1979.1142057>
- Malik, P. K. (2021). Planar Antennas: Design and Applications. In *Planar Antennas: Design and Applications*, 1, 364.
<https://doi.org/10.1201/9781003187325>
- Martin-Anton, S., & Segovia-Vargas, D. (2020). Fully Planar Dual-Polarized Broadband Antenna for 3G, 4G and Sub 6-GHz 5G Base Stations. *IEEE Access*, 1, 91940-91947.
<https://doi.org/10.1109/ACCESS.2020.2994382>
- Matta, L., Sharma, M., Kaur, P., & Sharma, B. (2022). Ultra Wideband Planar Monopole Antenna with Pair of C-Shaped Slots and T-Shaped Sleeve for Microwave Systems. *ECS Transactions*, 107, 6523.
<https://doi.org/10.1149/10701.6523ecst>
- Milligan, T. A. (2005). Modern Antenna Design: Second Edition. In *Modern Antenna Design: Second Edition*, 614.
<https://doi.org/10.1002/0471720615>
- Park, S., & Jung, K. Y. (2022). Novel Compact UWB Planar Monopole Antenna Using a Ribbon-Shaped Slot. *IEEE Access*, 10, 61951-61959.
<https://doi.org/10.1109/ACCESS.2022.3182443>
- Ramesh, M., & Yip, K. B. (2003). Design formula for inset fed microstrip patch antenna. *Journal of Microwaves and Optoelectronics*, 134, 1984.
- Rana, M. S., & Smieeee, M. M. R. (2022). Design and analysis of microstrip patch antenna for 5G wireless communication systems. *Bulletin of Electrical Engineering and Informatics*, 11(6), 3329-3337.
<https://doi.org/10.11591/eei.v11i6.3955>
- Rana, S., Thakur, A., Saini, H. S., Kumar, R., & Kumar, N. (2016). A wideband planar inverted F antenna for wireless communication devices. *Proceedings - 2016 International Conference on Advances in Computing, Communication and Automation, ICACCA*, 2, 875.
<https://doi.org/10.1109/ICACCA.2016.7578875>
- Ranaweera, C., Monti, P., Skubic, B., Wong, E., Furdek, M., Wosinska, L., Machuca, C. M., Nirmalathas, A., & Lim, C. (2019). Optical Transport Network Design for 5G Fixed Wireless Access. *Journal of Lightwave Technology*, 37(16), 3893-3901.
<https://doi.org/10.1109/JLT.2019.2921378>
- Rashid, Z. mohammed, & M. Jassim Al-Hindawi, A. (2019). Design of Adaptive Planar Microstrip Patch Array Operating at 28 GHz for 5G Smart Mobile System. *Kurdistan Journal of Applied*

Research, 4(2), 158-172.

<https://doi.org/10.24017/science.2019.2.16>

- Ravipati, C. B., & Shafai, L. (1999). A wide bandwidth circularly polarized microstrip antenna using a single feed. *IEEE Antennas and Propagation Society International Symposium: Wireless Technologies and Information Networks, APS 1999 - Held in Conjunction with USNC/URSI National Radio Science Meeting, (Cat. No. 99CH37010)*, 5639 <https://doi.org/10.1109/APS.1999.789126>
- Roy, A. A., Môm, J. M., & Igwe, G. A. (2013). Enhancing the Bandwidth of a Microstrip Patch Antenna using Slots Shaped Patch. *American Journal of Engineering Research (AJER)*, 2(9), 23-30. <https://doi.org/10.13140/RG.2.1.2479.7044>.
- Sasaki, K., Monnai, Y., Saijo, S., Fujita, R., Watanabe, H., Ishi-Hayase, J., Itoh, K. M., & Abe, E. (2016). Broadband, large-area microwave antenna for optically detected magnetic resonance of nitrogen-vacancy centers in diamond. *Review of Scientific Instruments*, 14, 1-6. <https://doi.org/10.1063/1.4952418>
- Simba, A. Y., Yamamoto, M., Nojima, T., & Itoh, K. (2007). Circularly polarised proximity-fed microstrip antenna with polarisation switching ability. *IET Microwaves, Antennas and Propagation*, 1(3), 658 – 665. <https://doi.org/10.1049/iet-map:20050273>
- Sun, Y. X., Leung, K. W., & Lu, K. (2021). Compact Dual Microwave/Millimeter-Wave Planar Shared-Aperture Antenna for Vehicle-to-Vehicle/5G Communications. *IEEE Transactions on Vehicular Technology*, 70(5), 5071-5076. <https://doi.org/10.1109/TVT.2021.3070353>
- Volakis, J. L. (2012). Antenna Engineering Handbook: Introduction and Fundamentals, Fourth Edition. In *McGraw-Hill Companies*, 612.

How to cite this Article:

Ravi Kumar, Anchal Garg, Heli Shah and Bhupinder Kaur (2023). Survey on performance parameters of planar microwave antennas. *International Journal of Experimental Research and Review*, 31, 186-194.

DOI : <https://doi.org/10.52756/10.52756/ijerr.2023.v31spl.017>



This work is licensed under a Creative Commons Attribution-NonCommercial-NoDerivatives 4.0 International License.