

A CURRENT RETENTION BASED PROTECTION ALGORITHM FOR DC MICROGRIDS

¹Nirupama P Srinivas and ²Sangeeta Modi

¹Student, Department of Electrical and Electronics Engineering, PES University, India

²Associate Professor, Department of Electrical and Electronics Engineering, PES University, India

Email: {¹nirupamasrinivas@pesu.pes.edu}

Abstract

Microgrids have been identified as a step towards goals of global green energy generation as they offer attractive options of renewable resource inclusion in decentralized energy networks, thus providing incentive towards meeting a booming energy demand sustainably. They are however impaired by the characteristic nature of Distributed Renewable Energy Resources (DRERs). While DRERs and microgrids offer the advantage of sustainable energy generation and autonomous operation with respect to the traditional grid, their intermittency and unconventional characteristics due to deviation from the traditional power grid structures causes trepidation while opting for them. A cause of concern while employing microgrids in daily use is the peril to personnel and equipment during the occurrence of a fault. To mitigate severe loss of life and property, it is important to develop and design protection algorithms for microgrids. While there is a comparatively large pool of knowledge on AC microgrid protection, DC microgrid protection is challenging and is being focused on by researchers around the world. The unorthodox nature of these networks cause conventional protection algorithms to be unsuitable and make the protection of these microgrids tasking. The work in this paper aims to contribute to efforts in the protection of hybrid microgrids. While the work in this paper is limited to the DC side of the grid, the proposed algorithm is able to detect and identify the location of various types of DC faults. The algorithm is verified on a secondary radial hybrid microgrid and is further compared with existing DC protection algorithms on various performance parameters.

Abstract – Microgrids, Modern Power Systems, Protection of Power Systems, DC Faults, Distributed Generation

1. Introduction

Global trends in power system studies are mobilizing towards on-site generation and disconnection from the traditional power grid. Apart from the challenges associated with the conventional power grid, the incentive towards shifting to renewable energy resources to meet electricity demand can be causal to this mobilization. The traditional grid uses fossil fuels to generate electricity, which are on the verge of depletion.

One of the main problems associated with renewable resources is their intermittency. [1] While the supply shortfall and surplus is solved by connection to the main grid and energy storage systems, serious challenges are caused in their current and voltage. Due to their inherent characteristic to be intermittent in nature, they can have varying current and voltage levels.

Of late, renewable resources have been employed in autonomous structures, called as microgrids. Microgrids are structures that consist of generational components, power electronic converters, and electrical loads that can operate autonomously from the traditional power grid. They can be controlled independently, and promote the idea of decentralized, dispersed generation. Due to the presence of various decentralized energy resources, like

solar energy and wind energy sources, there is a bidirectional flow of power.

This unique characteristic combined with the renewable intermittency causes challenges local to microgrids, including problems related to power quality, harmonics, and protection against faults. While AC protection in microgrids has seen a large amount of attention, DC protection in microgrids has proven to be complex to solve, as conventional algorithms prove futile in the protection of systems against DC faults. [2]

This work intends to contribute to the work in the protection of microgrids. The system under consideration is a hybrid microgrid with the point of mutual coupling kept open, so the system functions autonomously.

The paper can be understood in nine sections. The opening section introduces the challenges in microgrids, followed by a section on DC faults in power systems. The third section presents the system under consideration followed by the fault analysis of the same. The fifth section presents the proposed algorithm, while the succeeding segment of the paper presents the algorithms consequences on the structure under study. The following segment presents a comparison of the proposed algorithm with two existing algorithms and concludes with the analysis of the results and future work.

2. Challenges Associated with Microgrids

While advantages of the microgrid include implementing islanding, improve service quality, and scalability. [5] Few of the challenges include

- a. Voltage and Frequency Issues
- b. Power Quality Issues
- c. Resynchronization to the Traditional Grid
- d. Energy Storage Issues in Microgrids
- e. Protection of the Microgrid Against Faults

Due to the unique characteristic of bidirectional power flow in a microgrid, conventional protection strategies are inefficient in detecting and locating faults and disturbances. [3] Moreover, the intermittency of renewable resources can cause varying fault current levels. Thus adaptive protective devices and algorithms are required in order to detect and isolate faulty portions of the microgrid.

Moreover, the protection algorithm for a renewable based microgrid should be intelligent, as irradiation or wind speed caused current and voltage changes should not be identified as a fault by a controller [4].

3. Faults in Power Systems

A fault or a disturbance in a power system is termed as an atypical state that involves the failure of electrical apparatus. Faults are conventionally characterized by an abnormal variation in current, and even voltage levels. They can be caused due to heavy rains, aging infrastructure, insulation failure, physical damage, and human error. Faults carry potential to cause severe impairment to life and property. Conventionally, faults are classified into short circuit faults (SC faults) and open circuit faults (OC faults). [6]

3.1 Short Circuit Faults

SC faults, or shunt faults, are caused due to very small impedance between two locations of dissimilar potential. Short circuit faults are usually caused due to collapse of transmission lines, insulation aging and weakening, improper installation, overloading of equipment, mechanical damages due to external factors, and insulation failure due to lightning strikes.

3.2 Open Circuit Faults

Open circuit faults or series faults occur due to the mis operation of one or more conductors. They produce an unbalance in voltages, causing serious damages to personnel and equipment. While open circuit faults are not as severe and dangerous as short circuit faults, they can still potentially cause damage to equipment, life, and property. [15]

3.3 Classification Based on Power

While classifying faults according to their type of power, faults are classified into AC faults and DC faults.

3.3.1. AC Faults

Most power systems in today's world are AC based. Three phase systems are widely used for AC power transmission and distribution. The phases might be star or delta connected, which the neutral point of the star connection grounded. [14] AC systems usually have three phases, and their faults are classified into

- Line-to-line-to-line fault
- Line-to-ground fault
- Line-to-line-to-ground fault
- Line-to-line-to-line-to-ground fault
- Line-to-line fault

While line to line to line is the most severe, it is the most uncommon in practical occurrence. Line to ground, or LG faults are the least severe, and around 70% of global fault occurrences are of this type. [7]

3.3.2. DC Faults

While AC systems can have three to four conductors, DC systems have only 2 conductors, or phases. DC faults occur in two categories, pole-to-pole faults (SC faults) or pole-to-ground faults (OC faults).

- Pole-to-Pole Faults

Pole-to-pole faults in DC systems arise due to the straight connection or insulation collapse between positive and negative conductors of a transmission line in a DC system. While this type of fault is relatively uncommon, they are causal to severe damage, including destroying power switches and massive power interruptions. DC pole-to-pole disturbances are more detectable and dangerous [8].

- Pole-to-Ground Faults

DC pole-to-ground faults ensue due to the failure of one or more conductors. They are high impedance faults and are generally less severe than pole-to-pole faults and relatively more difficult to detect. However, they should be detected and cleared in a fast time period as they can cause damage to personnel and apparatus. [9]

The study of its fault characteristics is of real-world consequence for the protection of power system. Unlike AC systems, there is no significance of a frequency component in DC systems. Thus, the two primary parameters for the identification of a pole-to-pole fault in a DC system are the voltage and current.

4. Challenges with DC Protection

The main challenges with DC protection are related to the detection and identification of faults. While pole-to-pole faults in a DC system are easily observable, pole-to-ground

faults are difficult to observe due to their minute changes in current and voltage levels.

4.1 Absence of Zero Crossing

One of the primary trials with DC fortification is the nonappearance of zero-crossing in the current of DC systems. Thus, faults are not easily intervened using circuit breakers and conventional AC protection devices. [10]

4.2 Arcing and Fault Clearing Time

High fault clearing time and the arcing tendency are drawbacks of conventional DC protective devices, or switches. Thus, economically feasible protective devices are to be advanced for the fortification of DC systems with minimal operational time and reduced or no arcing.

4.3 Issues Related to Stability

With the onset of renewable energy resources and decentralized energy generation, changes in power due to the intermittency of renewable resources, changes in load power, and disturbances from the traditional power grid may cause temporary, transient disturbances. The disturbances may be augmented by power electronic converters.

4.4 Rapid Discharge of Capacitors

DC systems have capacitive filters to improve power quality, and these capacitors can rapidly discharge into a fault, resulting in excessively high fault currents. With respect to protective devices, these fault currents can cause nuisance tripping in healthy regions of the grid, which results in unnecessary loss of power.

4.5 Guidelines and Standards

An important challenge in practically realizing a safe Dc system to function in is the lack of standards and guidelines for power system engineers to adhere to. There is requirement to develop standards in the protection and safety aspect of DC systems, along with the requirement of robust standards related to communication protocols within the microgrid, islanded and grid connected mode, power quality, grounding, and nominal system voltages.

Moreover, the lack of abundant DC microgrid systems or test beds for researchers to carry out experiments is a further deterrent, as most researchers rely on simulation software, which can produce results different from a practical scenario [9-10].

5. System Under Consideration

The system under study, as per Fig. 1, in this paper is a
ISSN (Print): 2456-6411 | ISSN (Online): 2456-6403

microgrid can be discretized into two sections, the AC section and the DC section. [11] The AC section is interfaced to the utility grid, with the PCC kept open. The AC section also contains 3 AC Loads of constant demand.

The DC section of the microgrid is interlinked to two photovoltaic arrays supplying a total of 100.72kW and 3 DC loads, with a total demand of 100kW.

The AC and the DC sections of the microgrid are coupled through a bidirectional converter. As the PCC is disconnected, the microgrid functions in an autonomous mode. The system is simulated in Simulink and MATLAB. The faults in this system are created through an ideal switch to simulate the fault.

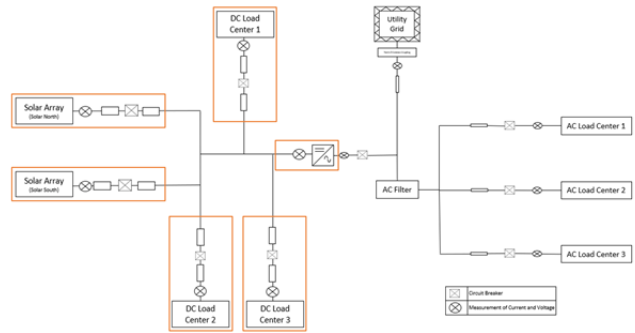

Fig. 1. System Under Consideration

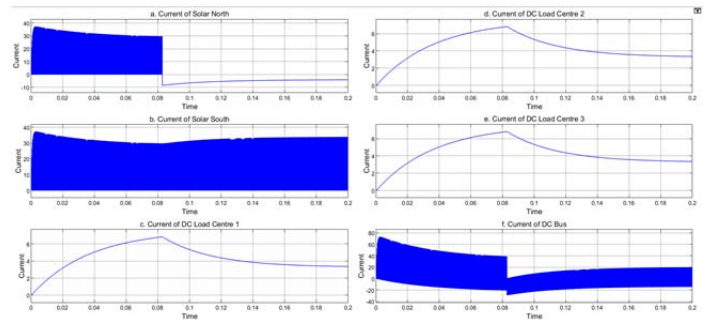

Fig. 2. Current in the System during a Pole-to-Pole Fault in Solar North Zone

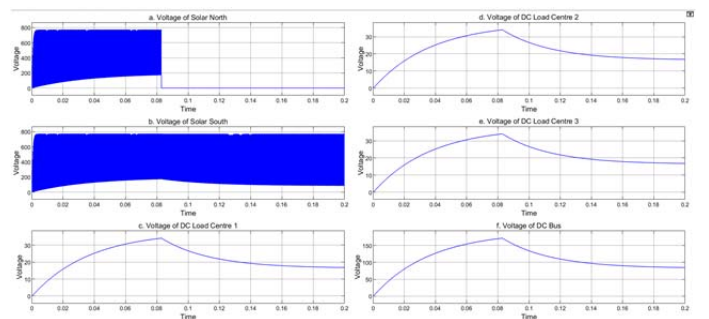

Fig. 3. Voltage in the System during a Pole-to-Pole Fault in Solar North Zone

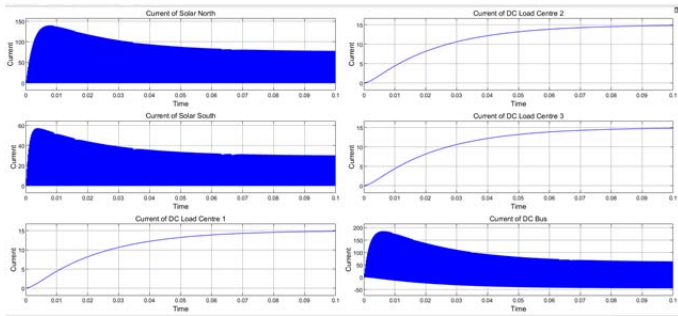

Fig. 4. Current in the System during a Pole-to-Ground Fault in Solar North Zone

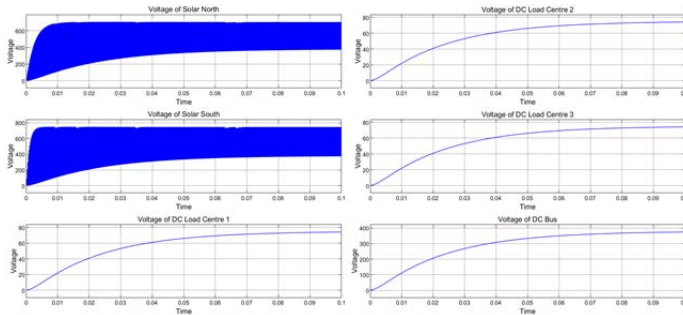

Fig. 5. Voltage in the System during a Pole-to-Ground Fault in Solar North Zone

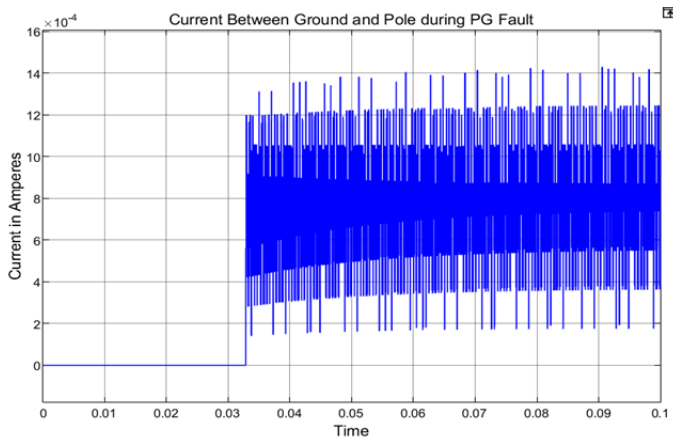

Fig. 6. Current Between the Ground and Pole during a Pole-to-Ground Fault

6. Fault Analysis of the System

The studied network is analyzed for pole-to-pole pole-to-ground faults in this section. This is essential in developing a robust algorithm for the protection of the system.

Fig. 2 represents the current waveform when a pole to pole fault is created in the North Solar Zone. As observed, Fig. 2.a represents the current through the faulted zone, i.e. the solar north zone. As per the figure, the current in the Solar North Zone changes from 30A pre-fault to -10A post-fault, a change of almost 40A. Table 1 presents the current change in all the zones as per the observations in Fig. 2.

Fig. 3 represents the voltage waveform when a pole-to-

pole fault is created in the North Solar Zone. As observed, Fig. 3.a represents the voltage through the faulted zone, i.e. the solar north zone. As per the figure, the voltage changes from 780V pre-fault to 0V post-fault, a change of almost 780V. Table 2 presents the voltage change in all the zones as per the observations in Fig. 3.

Fig. 4 presents the current waveforms when a pole to ground fault has been created at the Solar North Zone of the system under consideration at a simulation time of 0.033 seconds. For convenience, the figure is studied in six sections.

Fig. 4.a represents the current during the Solar North Zone and Fig. 4.b represents the current in the Solar South Zone. Fig. 4.c, Fig. 4.d, and Fig. 4.e represents the currents through DC Load Centre 1, DC Load Centre 2, and DC Load Centre 3. The current through the DC Bus is presented in Fig. 4.f. Similarly, Fig. 5 represents the voltages across all the six zones in the system when the pole to ground fault is created in the Solar North Zone.

As per Fig. 4, no significant change is observed when the fault is created. However, while measuring current between the pole and the ground, as per Fig. 6, there is a discharge of current to ground. As the current flowing to the ground is in the order of mA, it is comparatively much lesser than the normal values of current. However, this current flow can still cause impairment, and it is ideal to clear the fault by identifying the location of the fault and isolating it from the unfaulted, healthy section of the grid.

Table 1

Current Of the System During a Pole-to-Pole Fault in Solar North

Zone	Figure	Prefault Current	Postfault Current
Solar North	Fig. 2.a	30 A	-10 A
Solar South	Fig. 2.b	30 A	35 A
DC Load Centre 1	Fig. 2.c	6.6 A	3.8 A
DC Load Centre 2	Fig. 2.d	6.6 A	3.8 A
DC Load Centre 3	Fig. 2.e	6.6 A	3.8 A
DC Bus	Fig. 2.f	40 A	10 A

Table 2

Voltage Of the System During a Pole-to-Pole Fault in Solar North

Zone	Figure	Prefault Voltage	Postfault Voltage
Solar North	Fig. 3.a	780 V	0 V
Solar South	Fig. 3.b	780 V	Change in Lower Transient
DC Load Centre 1	Fig. 3.c	32 V	17 V

DC Load Centre 2	Fig. 3.d	32 V	17 V
DC Load Centre 3	Fig. 3.e	32 V	17 V
DC Bus	Fig. 3.a	780 V	0 V

7. Algorithm for Protection

This section presents the proposed algorithm for the protection of microgrids against faults. The memory based algorithm proposed is used to detect and identify the location of pole-to-pole and pole to ground faults in the system under consideration.

One of the most significant indicators during a fault is the change in current in the faulted zone. Moreover, the propagation of fault current is observed as the current values in unfaulted zones change. This algorithm employs the current values of various zones to determine the presence and location of a fault. Fig. 7 presents the flowchart of the algorithm proposed.

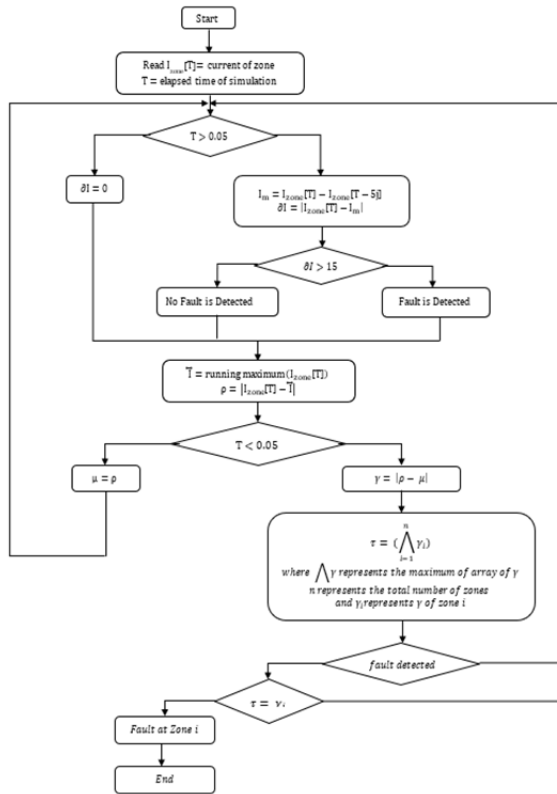

Fig. 7. Proposed Algorithm for Fault Detection and Location Identification

As per the fault analysis, and reference, pole to ground faults, although not as severe, do have effect on the system studied. As there is time taken for the system to reach steady state, employing the algorithm during transient state of the system would provide incorrect details about the status, and would cause false tripping of the system.

Thus, a prerequisite of 0.05 seconds of simulation time is suggested as a “wait period” before applying the

proposed algorithm. The algorithm uses memory block to compute the previous values of current of the zone. Where $I_{zone} [T]$ represents the current of a zone at simulation time T ; where T represents the elapsed simulation time at any instant, and j represents the sample time of the system.

The algorithm computes the difference between the value of the current at time T and the value of current five samples ago. The difference between the current during time T and the current five samples ago.

$$I_m = I_{zone}[T] - I_{zone}[T - 5j]$$

$$\partial I = |I_{zone}[T] - I_m|$$

$$if \partial I > 15$$

A fault is detected in the system if the difference of the two currents is greater than 15A. Further, the running maximum [reference] of the current of the considered zone ($I_{zone} [T]$) is calculated and subtracted from $I_{zone} [T]$.

$$\bar{T} = \text{running maximum}(I_{zone}[T])$$

$$\rho = |I_{zone}[T] - \bar{T}|$$

If the elapsed time of simulation is less than 0.05 seconds, ρ is stored in memory as μ . If the elapsed time of simulation is above 0.05 seconds,

$$\gamma = |\rho - \mu|$$

$$\tau = \left(\bigwedge_{i=1}^n \gamma_i \right)$$

where $\bigwedge \gamma$ represents the maximum of array of γ n represents the total number of zones and γ_i represents γ of zone i

If $\tau = \gamma_i$, a fault is identified in zone i . The output of the system is numeric, identifying the zone of where the fault has occurred. Table 3 presents the mapping of the controller’s numeric output to the zone of the system.

Table 3

Numerical Legend to the Status of the System Under Consideration

Output of Controller	Status of the System
0	Normal Conditions
1	Fault at the Solar North Zone
2	Fault at the Solar North Zone
3	Fault at DC Load Centre 1
4	Fault at DC Load Centre 2
5	Fault at DC Load Centre 3
6	Fault at DC Bus

8. Results and Analysis

Fig. 8 presents the controller’s output when the algorithm is when employed on the system under study and a pole-to-ground fault is created in the solar north zone. The fault is created at 0.057 seconds of simulation. As per Fig. 8, the controller provides an output 1, referring to the presence of a fault in the Solar North Zone.

A pole-to-ground fault is simulated in the Solar South Zone, and the controller results are displayed in Fig. 9. The results display a controller output of 2, and as per Table 3, represent the presence of a fault in the Solar South Zone. The fault is created around 0.055 seconds into simulation time.

While the controller is accurately able to detect and recognize the location of a fault, the controller is incapable of differentiating between a pole-to-pole fault and a pole to ground fault.

Considering that each step of computation in the controller takes one sample to execute, the total time of detection and isolation would be 15 times the sample time.

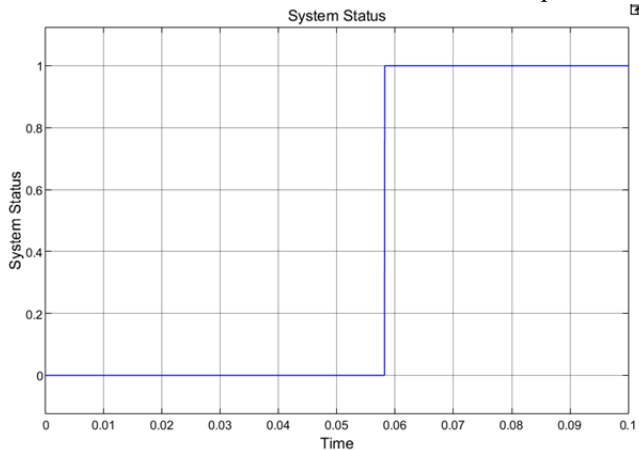

Fig. 8. Controller Output During a Pole-to-Pole Fault at Solar North

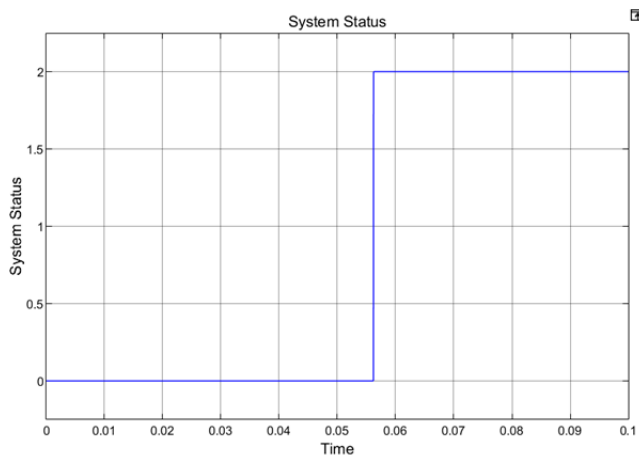

Fig. 9. Controller Output During a Pole-to-Ground Fault at Solar South

9. Comparison with Existing Algorithms

Table 4 presents a comparison between existing DC

protection algorithms. Energy Transient Algorithm refers to the algorithm presented in [12], Memory Algorithm refers to the algorithm presented in [11], and Modified Memory Algorithm refers to the algorithm presented in this work. The algorithms are compared the following parameters of –

9.1 Sensitivity

Pole to ground faults are less detectable than pole-to-pole faults as pole to ground faults have lesser current and voltage change likened to pole-to-pole faults. This leads to difficulty in the detection of pole to ground faults.

9.2 Selectivity

When a microgrid is affected by a fault, minimum power interruption should be ensured so customers connected to the microgrid suffer least power interruption. To ensure least power interrupts, solely the faulty section must be identified and isolated from the grid in a fast amount of time. This ensures that healthy sections of the microgrid do not suffer power loss and there is least propagation of the fault.

9.3 Reliability

The algorithm on which the controller functions must be able to detect faults accurately in the system. The algorithm must not falsely detect faults due to irradiation changes, changes in grid connection, and must not be blind to faults due to variation of fault current levels due to the intermittency of renewable resources.

9.4 Speed

The protection of the algorithm must be able to detect faults and isolate faulty sections of the microgrid in a considerably speedy amount of time to minimize damages and mitigate the propagation of faults to healthy sections of the system. [5]

While the algorithm proposed in this figure is superior to the memory algorithm and the energy transient algorithm in terms of sensitivity, selectivity, and reliability with respect to the system under consideration. However, due to the high number of computations in the Modified Memory Algorithm, the algorithm is inferior in speed as compared to the Energy Transient Algorithm and the Memory Algorithm, which have lower number of computational steps.

Table 4

Comparison of Existing Algorithms with the Proposed Algorithm

Algorithm	Selectivity		Fault Location	Speed
	Pole	Pole to		

	to Pole	Ground		
Energy Transient	Yes	No	No	5*j
Memory Algorithm	Yes	No	No	5*j
Modified Memory Algorithm	Yes	Yes	Yes	15*j

10. Conclusion and Future Work

While designing a suitable protection algorithm for a system, it is important to make an optimal compromise between various performance parameters to optimize protection for the structure under contemplation.

The algorithm in this paper aids in detecting and identifying the location of pole to ground and pole-to-pole faults in the structure under study. However, the algorithm is unable to differentiate between pole-to-pole and pole to ground faults and marks large current changes due to changes in system configurations as faults. With a higher amount of severity of pole-to-pole faults as compared to pole-to-ground faults, it is important to consider the potential of damage to life and property by each type of fault before selecting a protective device.

Future work can be carried out in improving the speed of the detection of the algorithm and the algorithmic

discernment between pole to ground and pole to pole faults. Large current changes which are not caused by faults are identified as faults by the proposed algorithm. Work should be carried out on the identification of whether a current change is a system change or a disturbance. Further, there is a necessity for the robust definition of DC protection devices. There is a requirement for DC protection devices with competent tripping time and work needs to be carried out in this direction as well. [13]

The algorithm proposed in this paper was further verified on a hybrid microgrid with a photovoltaic array, wind turbine, and an energy storage system. The system employed for verification has one DC load and three AC loads.

References

- [1] N. Srinivas, S. Singh, M. Gowda, C. Prasanna and S. Modi, "Comparative Analysis of Traditional and Soft Computing Techniques of MPPT in PV Applications," 2021 IEEE 4th International Conference on Computing, Power and Communication Technologies (GUCON), 2021, pp. 1-6, doi: 10.1109/GUCON50781.2021.9573876.
- [2] Salam, A. & Mohamed, Azah & Hannan, M. A. (2008). Technical Challenges of Microgrids. ARPN Journal of Engineering and Applied Sciences. 3. 64-69.
- [3] Nirupama P Srinivas and Sangeeta Modi 2022 ECS Trans. 107 13345.
- [4] Z. Ali et al., "Fault Management in DC Microgrids: A Review of Challenges, Countermeasures, and Future Research Trends," in IEEE Access, vol. 9, pp. 128032-128054, 2021, doi: 10.1109/ACCESS.2021.3112383.
- [5] N. Srinivas and S. Modi, "A Comprehensive Review of Microgrid Challenges and Protection Schemes", SPAST Abs, vol. 1, no. 01, Oct. 2021
- [6] Augustine, Sijo, & Quiroz, Jimmy & Reno, Matthew & Brahma, Sukumar. (2018). DC Microgrid Protection: Review and Challenges.
- [7] J. Gudex and R. Cuzner, "Multiple Line-to-Ground Fault Characterization and Mitigation in MVDC Shipboard Electrical Systems," 2021 IEEE Electric Ship Technologies Symposium (ESTS), 2021, pp. 1-9, doi: 10.1109/ESTS49166.2021.9512316.

- [8] S. S. Dessouky, M. Fawzi, H. A. Ibrahim & N. F. Ibrahim, "DC Pole to Pole Short Circuit Fault Analysis in VSC-HVDC Transmission System," 2018 Twentieth International Middle East Power Systems Conference (MEPCON), 2018, pp. 900-904, doi: 10.1109/MEPCON.2018.8635237.
- [9] Yang, Xiaofeng & Xue, Yao & Wen, Piao & Li, Zejie. (2018). Comprehensive Understanding of DC Pole-to-Pole Fault and Its Protection for Modular Multilevel Converters. 3. 246-254. 10.1049/hve.2018.5045
- [10] Durgaprasad S., Nagaraja S., Modi S. (2022) HVDC Fault Analysis and Protection Scheme. In: P. S., Prabhu N., K. S. (eds) Advances in Renewable Energy and Electric Vehicles. Lecture Notes in Electrical Engineering, vol 767. Springer, Singapore. https://doi.org/10.1007/978-981-16-1642-6_18.
- [11] Nirupama P Srinivas, Sangeeta Modi. "A Memory Based Current Algorithm for Pole-to-Pole Fault Detection in Microgrids", Volume 10, Issue V, International Journal for Research in Applied Science and Engineering Technology (IJRASET) Page No: 365-377, doi: 10.22214/ijraset.2022.42182
- [12] N. P. Srinivas and S. Modi, "Pole-to-Pole Fault Detection Algorithm Using Energy Slope for Microgrids," 2022 International Conference on Electronics and Renewable Systems (ICEARS), 2022, pp. 288-294, doi:10.1109/ICEARS53579.2022.9752299
- [13] M Sanath Kumar , G Pavan Kumar , Fakeerappa Rathod , Sangeeta Modi, 2022, Cell Balancing in Electric Vehicle Battery Pack, INTERNATIONAL JOURNAL OF ENGINEERING RESEARCH & TECHNOLOGY (IJERT) Volume 11, Issue 04 (April 2022),
- [14] "Applications of Artificial Intelligence Techniques in Engineering", Springer Science and Business Media LLC, 2019
- [15] Patrick T. Lewis, Brandon M. Grainger, Hashim A. Al Hassan, Ansel Barchowsky, Gregory F. Reed. "Fault Section Identification Protection Algorithm for Modular Multilevel Converter- Based High Voltage DC With a Hybrid Transmission Corridor", IEEE Transactions on Industrial Electronics, 2016
- [16] Yongjun Xu, Yuan Hu, Guoquan Li, Haibo Zhang. "Robust resource allocation for heterogeneous wireless network: a worst-case optimisation", IET Communications, 2018